

HS 声力电话系统

HS Series Batteryless Telephone System



杭州华雁数码电子有限公司
HANGZHOU HUAYAN DIGITAL ELECTRON CO., LTD.

目 录 CONTENTS

1 概述	1
2 主要功能	1
3 技术性能	1
4. 技术指标	2
5 系统组成	2
6 直通声力电话系统操作说明	2
7 选通声力电话系统操作说明	3
8 指挥声力电话系统操作说明	3
9 开通维护及注意事项	4
1 General	5
2 Main functions	5
3 Technical performance	6
4 Technical indexes	6
5 System composition	6
6 Instructions for operation of interphone batteryless telephone system	7
7 Instructions for operation of gating batteryless telephone system	7
8 Instructions for operation of command batteryless telephone system	8
9 Turn-on, maintenance and points for attention	9
Appendix	10
Installation diagram system wiring drawings	10

附录 Appendix

安装尺寸图和系统接线图 Installation diagram system wiring drawings

1: HSQ-1 嵌入式直通型声力电话机 Flush-type interphone batteryless telephone set

2: HSG-1 壁挂式直通型声力电话机 wall-mounted interphone batteryless telephone set

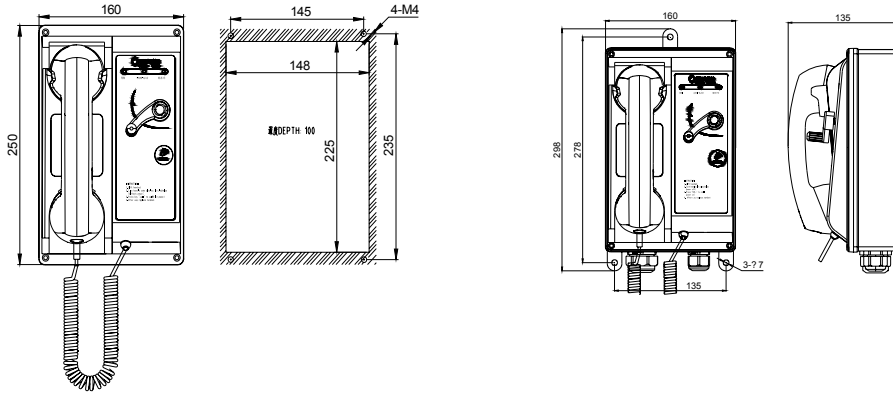

3: 直通型声力电话机系统接线图 Interphone batteryless telephone system connection diagram

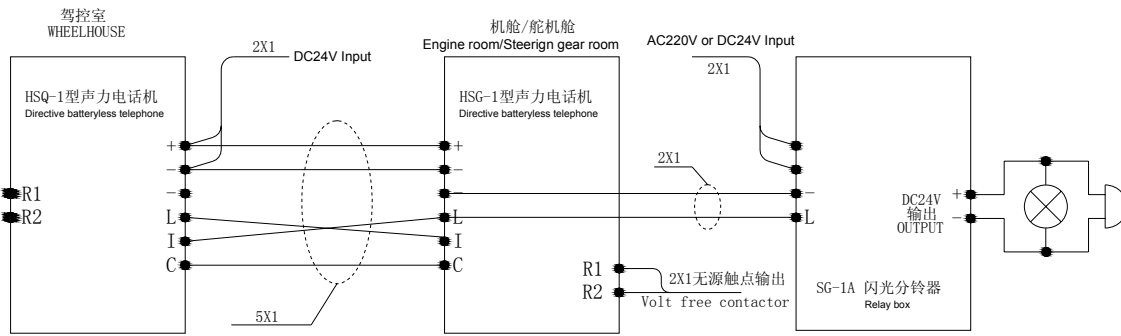

接线标号功能说明

Instructions for connection and labeling function:

I: 发讯线 transmitting line

C: 通话线 speaking line

L: 收讯线 receiving line

+: 电源正极线 power positive pole line -: 电源负极线 power negative pole line

注: 接线时收、发讯线交叉 (收讯线接发讯线; 发讯线接收讯线)

Note: receiving and transmitting lines cross when connecting (receiving line connects transmitting line; transmitting wire connects receiving line)

4. 6HSG-1T 6 门头戴壁挂式选通声力电话机 6-way headset/wall-mounted gating batteryless telephone set

5. HSG-1F 防风雨式声力电话机 weather-proof batteryless telephone set

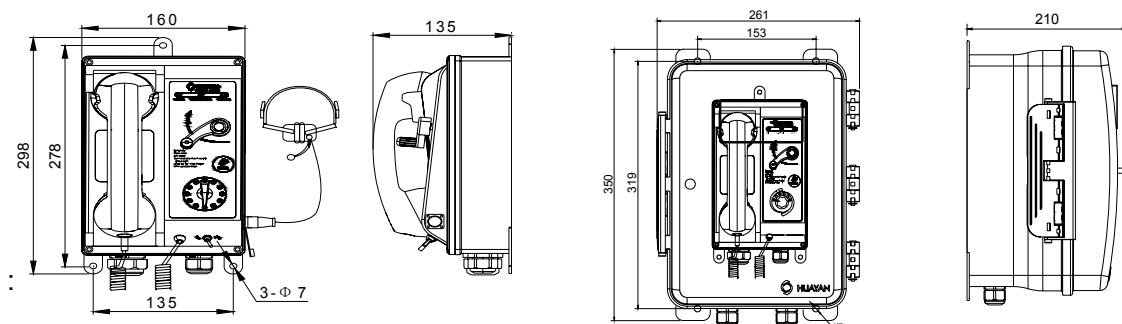

6: 6HSQ -1 嵌入式 6 门 选通声力电话机 flush-type 6 ways gating batteryless telephone set

7: 6HSG -1 壁挂式 6 门选通声力电话机 wall-mounted 6-way gating batteryless telephone set

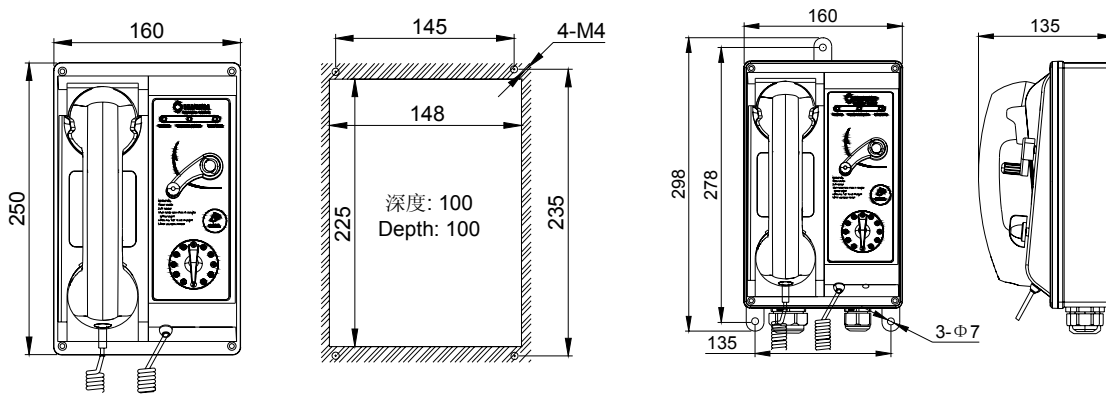

8: 12HJ-1 12 门汇接箱 12-way junction box

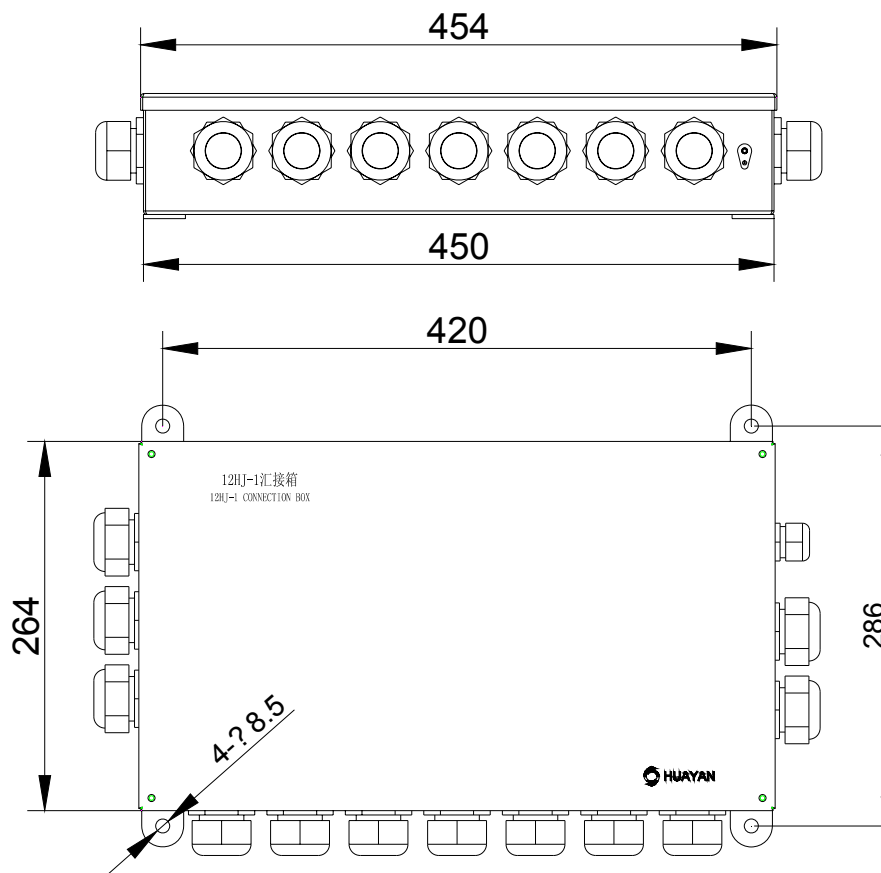

型号 Model	防护等级 IP Rating	外形尺寸及安装尺寸 Outline and Mounting Dimensions						重量 Weight
		W	H	D	W1	A	B	
6HJ-1	IP22	395	265	82	PG16	360	240	3.9kg
6HJ-1	IP44	395	265	82	PG16	360	240	4.3kg
12HJ-1	IP22	460	330	82	M32	420	300	5.4kg
12HJ-1	IP44	460	330	82	M32	420	300	5.6kg
16HJ-1	IP44	614	300	82	M32	420	300	7.6kg

9: 6 门选通声力电话系统接线图 6-way gating batteryless telephone system connection diagram

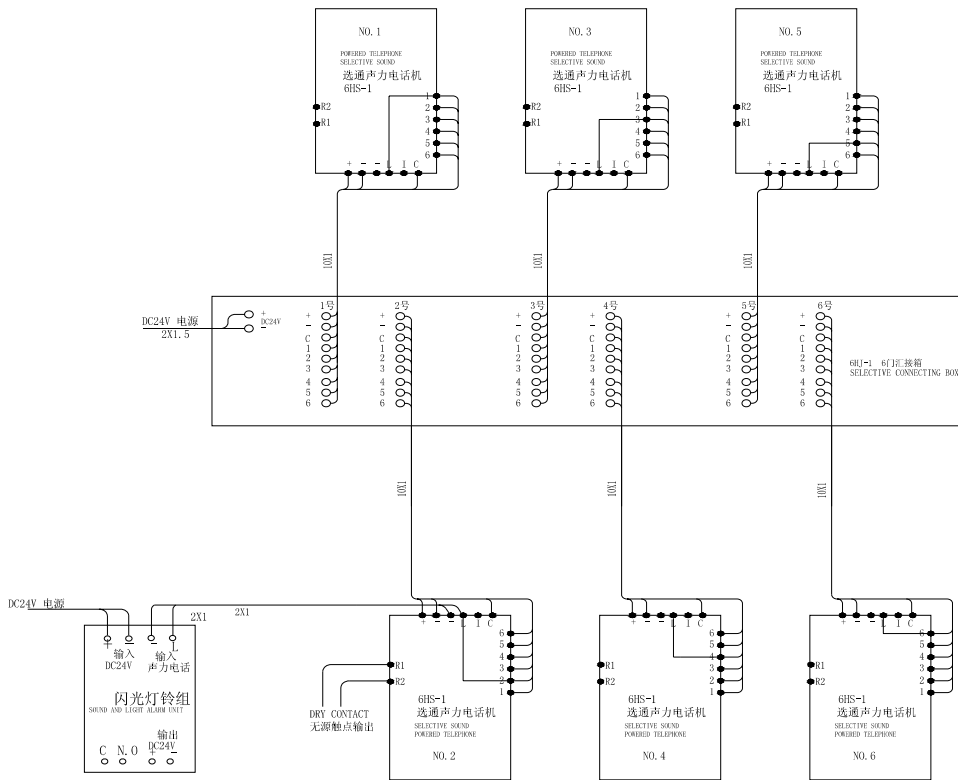

选通声力电话与汇接箱接线说明:

选通电话机相应标号与汇接箱相应端子依次对应: 1, 2, 3, 4, 5, 6, C, -, + 选通电话"L" 线与本机号相连
 Instructions for connection of gating batteryless telephone set and junction box: Gate set corresponding label and junction box corresponding terminal in turn correspond to: 1, 2, 3, 4, 5, 6, C, -, +, gating telephone "L" line is connected with the number of this set

- 10: 12HSQ-1 嵌入式 12 门选通声力电话机 flush-type 12ways gating batteryless telephone set
- 11: 12HSG-1 壁挂式 12 门选通声力电话 wall-mounted 12way gating batteryless telephone set

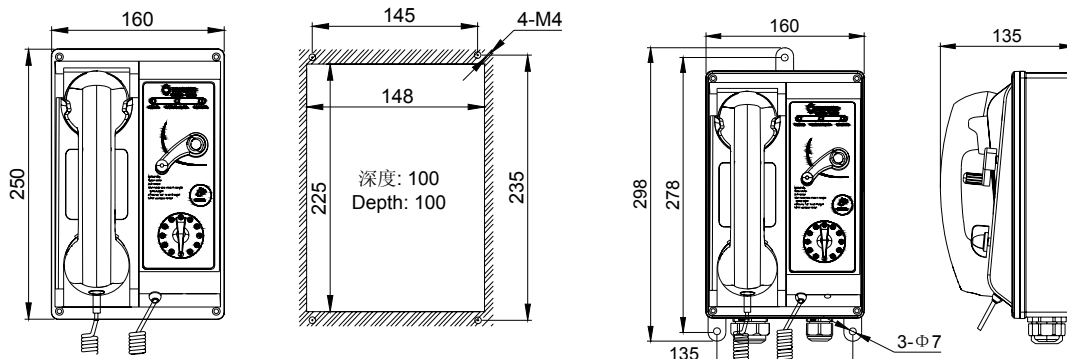

12 12 门选通声力电话系统接线图 12-way gating batteryless telephone system connection diagram

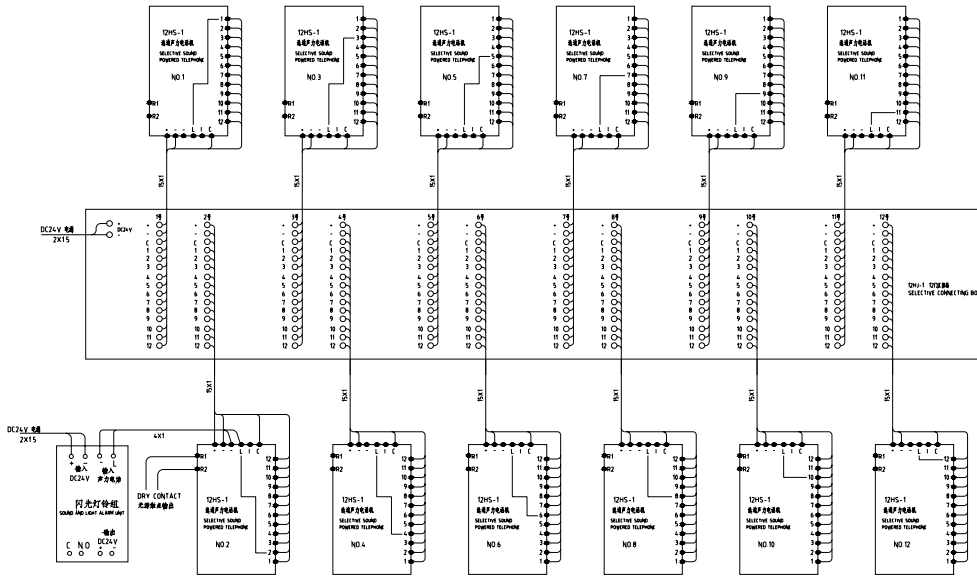

选通声力电话与汇接箱接线说明:

选通电话机相应标号与汇接箱相应端子依次对应: 1, 2, 3, 4, 5, 6, 7, 8, 9, 10, 11, 12, C, -, + 选通电话"L"线与本机号相连

Instructions for connection of gating batteryless telephone set and junction box: Gate set corresponding label and junction box corresponding terminal in turn correspond to: 1, 2, 3, 4, 5, 6, 7, 8, 9, 10, 11, 12, C, -, +, gating telephone "L" line is connected with the number of this set.

13: 16HSQ-1 嵌入式 16 门选通声力电话机 flush-type 16ways gating batteryless telephone set

14: 16HSG-1 壁挂式 16 门选通声力电话 wall-mounted 16way gating batteryless telephone set

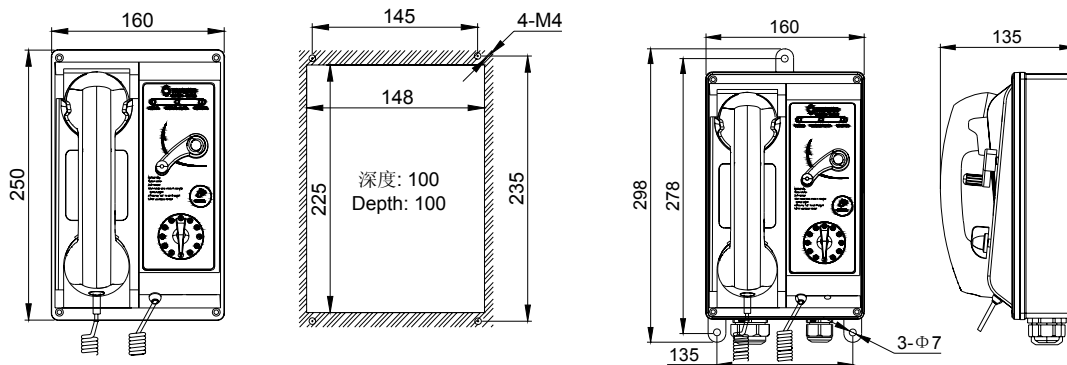

15 16 门选通声力电话系统接线图 16-way gating batteryless telephone system connection diagram

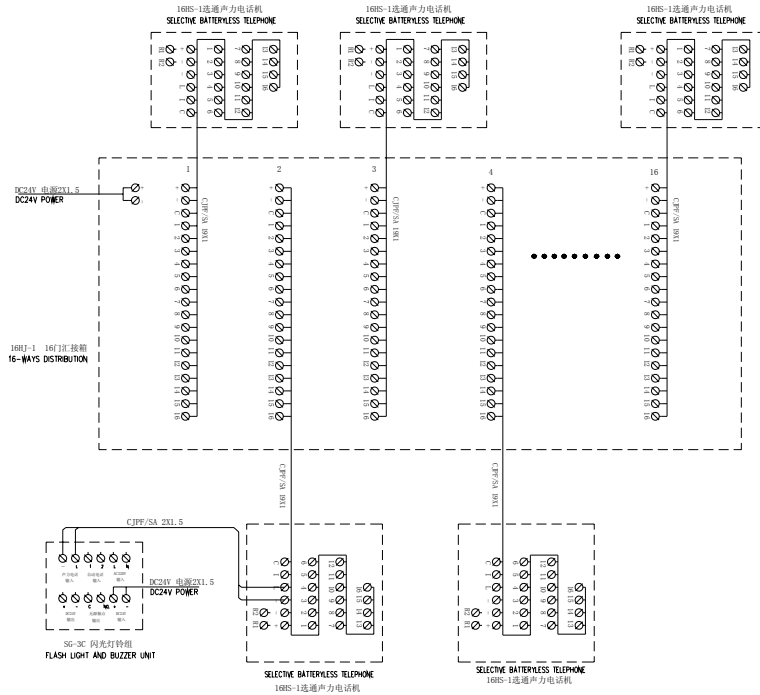

选通声力电话与汇接箱接线说明:

选通电话机相应标号与汇接箱相应端子依次对应: 1, 2, 3, 4, 5, 6, 7, 8, 9, 10, 11, 12, 13, 14, 15, 16, C, -, + 选通电话"L"线与本机号相连

Instructions for connection of gating batteryless telephone set and junction box: Gate set corresponding label and junction box corresponding terminal in turn correspond to: 1, 2, 3, 4, 5, 6, 7, 8, 9, 10, 11, 12, 13, 14, 15, 16, C, -, +, gating telephone "L" line is connected with the number of this set.

16: SG-3C 闪光灯铃组 flashlight buzzer unit

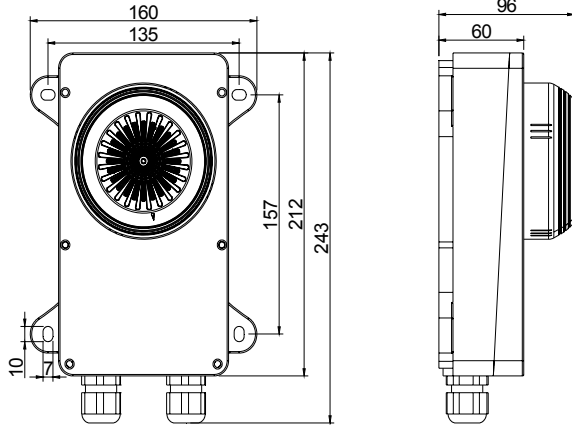

14: SG-1A 继电器盒 relay box

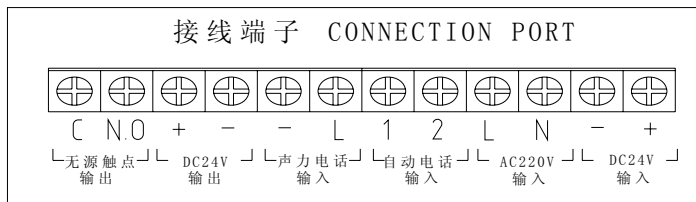
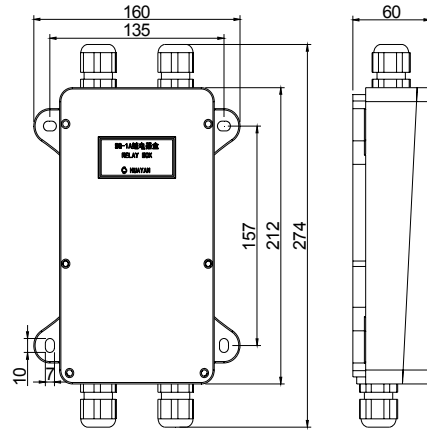

17: HSG-2E (6 门壁挂式选通) 防爆声力电话机 (6-way wall-mounted gating) explosion-proof batteryless telephone set

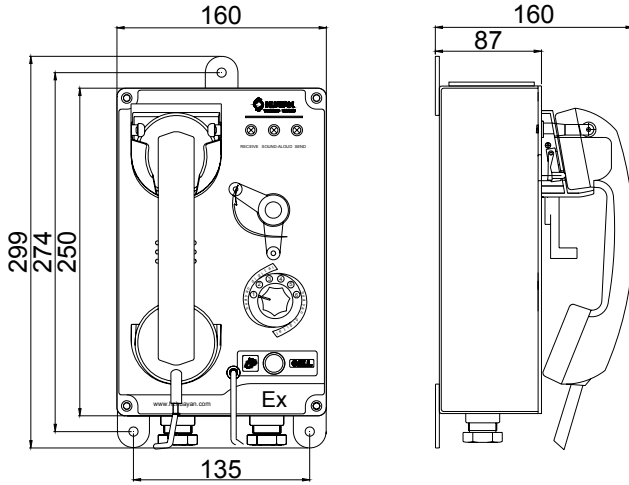

18: AQ-2 防爆安全栅 Explosion-proof safety barrier

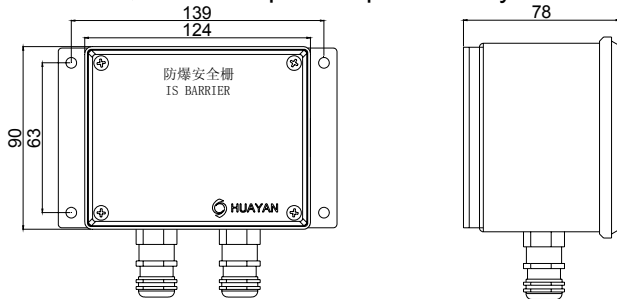

19: 6 门防爆选通声力电话机系统接线图

6-way explosion-proof gating batteryless telephone set system connection diagram

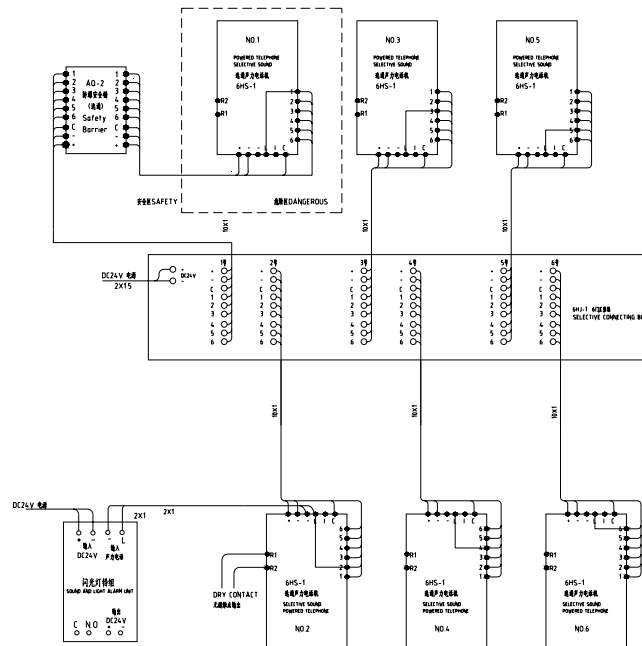

20: 防爆直通声力电话机接线图 Explosion-proof interphone batteryless telephone set connection diagram

