

CKY-1T 船用扩音机

CKT-1T Shipboard Public Address Set



杭州华雁数码电子有限公司
HANGZHOU HUAYAN DIGITAL ELECTRON CO., LTD.

目 录 Contents

一 概述	1
二 主要技术性能	2
三 设备型号及产品功能	3
四 系统组成	4
五 开通以及维护	5
六 安装注意事项	7
1 General	9
2 Main technical performance	10
3 Equipment model and production function	10
4 System composition	12
5 Turn-on and maintenance	14
6 Points for attention	16
Appendix	17
Installation diagram system wiring drawings	17

1 General

1.1 Use

1.1.1 CKY-1T/Q (Type F) shipboard public address set, a double power amplifier public address set, integrated with multiple useful functions such as intercom, command speaking and service speaking, is widely suitable for various ships as a device for order-transmitting command, speaking, external shout and theatrical broadcasting, and also suitable for broadcasting station in harbor, ocean project, industrial and mineral enterprises, stores and schools, etc.

1.2 Basic functions

1.2.1 This set can be operated in four modes:

1.2.1.1 Remote control operation

1.2.1.2 Automatic alarm start-up

1.2.1.3 Program-controlled telephone set

1.2.1.4 Broadcasting station operation

1.2.2 Control of this kind of set is carried out by different priority class:

1.2.2.1 Primary: emergency speaking (only limited to master remote control station)

1.2.2.2 Secondary: automatic alarm start-up

1.2.2.3 Class I: master remote control station

1.2.2.4 Class II: remote control station

1.2.2.5 Class III: telephone control

1.2.2.6 Class IV: main engine MIC and receiver/player

1.2.3 Broadcasting function

1.2.3.1 MIC speaking amplifying;

1.2.3.2 FM receiving and tape MP3 or CD player amplifying (MP3 or CD, optional by user);

1.2.3.3 7-way loudspeaker constant voltage output.

1.2.4 Remote control function

1.2.4.1 Broadcasting unit is equipped with external remote control station. With DC (DC24V) at the power supply end of the broadcasting unit, master remote control station can turn on the device in remote control manner to carry out PUBLIC(broadcasting) and control single-way or multi-way loudspeaker output. In alarming state, through master remote control station alarm can be switched off for emergency speaking to the entire ship.

1.2.4.2 Remote control speaking is characterized by priority classes. Master remote control station enjoys highest class, then No.2 and No.3 remote control stations respectively. Telephone remote control enjoys the lowest class.

1.2.5 Talkback function

1.2.5.1 Talkback can be realized between remote control stations and between intercom branch units.

1.2.6 Features

1.2.6.1 Main engine, adopting single-chip processor control technology, has overall performance improved. Remote control station in pilot's cabin has 6-core outgoing cable, other remote control stations and intercom branch units have 4-core outgoing cable. Main engine control console and functional enclosure can be mounted in split manner, of which main engine control console can be flush-type installed, and power amplifier enclosure desk-top.

1.2.6.2 Circuit has module design for easy plug-in and pull-out.

1.2.6.3 Shout, Deck 1, Deck 2, Cabin 1, Cabin 2, Post 1 and Post 2 loudspeakers have constant voltage output. Cabin 1, Cabin 2, Post 1 and Post 2 have output volume adjustable and function of forced full load output.

1.2.6.4 Power amplifier output is supported with short circuit and overload protections.

1.2.6.5 The overall unit adopts drawer plug-pull structure, characterized by simple combination and easy maintenance and adjustment.

1.2.6.6 Power supply: AC 220V±10% or DC24V±10%, automatic switching, AC priority;

2 Main technical performance

2.1 Suitable environmental conditions

2.1.1 Humidity:-10°C~+55°C

2.1.2 Relative humidity:35~75%

2.1.3 atmospheric pressure: 86~106Kpa

2.2Vibration

2.2.1 Sweep test: frequency1~35HZ, amplitude ±0.15~0.35MM, sweeping once

2.2.2 Fixed frequency test:frequency10HZ, amplitude ±1.00, 30minutes

2.3 Collision

2.3.1 Acceleration5g

2.3.1.1 Recurrence frequency 40~80times/minute, pulse duration:16MS, 1000times.

2.4 Slant, swing

2.4.1 Transverse swing: ± 22.5° longitudinal swing: ± 10°

2.4.2 Transverse slant: ± 22.5° Longitudinal slant: ± 10°

2.5 Technical indexes

2.5.1 Rated output power: 50W, 100W, 200W, 300W (Optional by user)

2.5.2 Non-linear distortion: ≤7%

2.5.3 Unevenness in pass band: ≤3dB

2.5.4 Input voltage: microphone ≤35mV (600Ω) line ≤150mV (600Ω)

2.5.5 Output voltage: 120V Signal-to-noise ratio: ≥50dB

2.5.6 Range of receiving frequency: medium wave 535~1605 KHz FM 87~108 MHz

2.5.7 Sensitivity: AM≤150uV FM≤20 uV

2.5.8 Playing frequency response: ≤8 dB 125HZ~8 KHz

2.5.9 Playing signal-to-noise ratio: ≥32 dB

2.6 Power supply: AC220V ± 10% DC24V ± 10%

2.7 Reference table of rated power, constant voltage output and power supply:

Rated output power	Power supply		Constant voltage output
	AC	DC	
50W	AC220V±10%/0.6A	DC24V±10%/5A	120V
100W	AC220V±10%/1A	DC24V±10%/9A	120V
200W	AC220V±10%/1.8A	DC24V±10%/16A	120V
300W	AC220V±10%/2.5A	DC24V±10%/20A	120V

3 Equipment model and production function

3.1 Model and configuration of the public address set

No	Configuration	CKY-1Q/A	CKY-1T/B	CKY-1T/C	CKY-1T/D	CKY-1Q	CKY-1T
1	—	Single power amplifier public address set				Dual power amplifier public address set	
2	Installation type	Flush-type	Desk-top	Desk-top	Flush-type	Flush-type	Desk-top
3	Quantity of power amplifier	1	1	1	1	2	2
4	Audio signal output power	50~100W	50~300W	50~300W	50~100W	50~300W	50~300W
5	AM/FM receiving, playing, MIC amplifying, MP3	√	√	√	√	√	√
6	Quantity of external remote control station for public broadcasting	8	8			8	8
7	General alarm interface	√	√	※	※	√	√
8	Dial telephone linkage public address set	√	√	※	※	√	√
9	Talkback between public address set, remote control station and intercom	√	√			√	√
10	Portable VHF wireless remote control	※	※			※	※
11	AC, DC auto changeover	√	√	√	√	√	√
12	Full load output in post and cabins by force	√	√	√	√	√	√

Note: "√" means the function is available, "※" means optional function.

PA with electric fog function is a customized product and must be specially manufactured.

3.2 Electric Performance

Output power of power amplifier	50W	100W	200W	300W
Constant voltage output of loudspeaker	120V	120V	120V	120V
Rated current (AC220V±10%)	0.5A	1A	2A	3.5A
Rated current (DC24V+30%,-25%)	5A	9A	20A	30A

3.3 Main technical indexes:

Nonlinear distortion	≤7%
----------------------	-----

Freq. response bandwidth	:100Hz~8KHz
Signal-to-noise ratio	:≥40dB MIC
Sensitivity	:≥8mV/Pa
Range of receiving frequency	: FM87.5 MHz~108MHz
Sensitivity of noise limit	: FM≤40μV
Playing frequency response	:100Hz~8KHz≤3dB

3.4 CKY-1Q, CKY-1T Dual power amplifier shipboard public address set

3.4.1 Functions and features:

AM/FM Receiver, CD Player
Seven output ports as Shout, Deck1, Deck 2, Post 1, Post 2, Cabin 1 and Cabin 2
Forced full-load output for Post 1, Post2, Cabin 1 and Cabin 2
Other output ports will be forced to close as shout output
Support 8 remote control stations (R.C.S)
Master remote control station can remotely control turn-on and select single way or multiway output
Remote control station has talkback function
Remote control station is capable of selecting 7 ways output.
Build in 2W loudspeaker as monitor
Dual amplifier outputs
General emergency alarm system interface
DC and AC could auto switchover
Power supply: Tow ways DC24V+30%, -25%(or AC220V±10%); Tow ways AC220V±10%,50Hz~60Hz

4 System composition

S. No.	Model	Description	IP Rating	Remark
1	CKY-1T/Q	Shipboard public address set	IP22	
2	YKQ-1Z	Flush-type master remote control station	IP20	
3	YKQ-1	Flush-type remote control station	IP20	
4	YKG-1	Wall-mounted remote control station	IP44	
5	YKG-1F	Weather-proof remote control station	IP56	
6	YKG -1E	Wall-mounted explosion-proof remote control station	IP44	ibIICT3
7	YKQ -1E	Flush-type explosion-proof remote control station	IP20	ibIICT3
8	AQ-3	Explosion-proof safety barrier	IP44	ibIICT3
9	YSQ	Flush-type loudspeaker	IP20	120V
10	YSG	Wall-mounted loudspeaker	IP22	120V
11	YSP	Drip-proof loudspeaker	IP44	120V
12	YSX	Ceiling-mounted loudspeaker	IP20	120V
13	YSS	Double-sided loudspeaker	IP22	120V
14	YHC	Horn-type loudspeaker	IP56	120V

15	YCQ-1	Flush-type microphone socket box (port/starboard)	IP20	
16	YCG-1	Wall-mounted microphone socket box (port/starboard)	IP44	
17	YXZ-1	Loudspeaker manual rotary platform	IP56	
18	YXD-1	Loudspeaker electric rotary platform	IP56	
19	YXD-1K	Loudspeaker electric rotary platform controller	IP20	
20	YS-1	Portable microphone	IP22	
21	YJ-1	Gooseneck microphone	IP20	

4.1 Public address set

4.1.1 Public address set consists of power supply circuit, amplifier circuit, receiver/player, input/output interface circuit, control circuit and output protection circuit, etc.

4.1.2 control circuit consists of single-chip processor and peripheral components and works for dynamic monitoring of all terminal devices and corresponding processing.

4.1.3 Amplifier circuit consists of input interface, front-mounting voltage amplifier and automatic gain control, etc. Input interface and front-mounting amplification is realized by adopting low-noise operation amplifier. Power amplifier circuit adopts transistor push-pull amplification circuit, and the output is equipped with overload protection. The circuit can be connected with loudspeaker externally, and track size of output volume of public address set. The monitoring loudspeaker is rated at 2W/8Ω.

4.1.4 Output loudspeaker has Shout, Deck 1, Deck 2, Cabin 1, Cabin 2, Post 1 and Post 2 7-way constant voltage output. Of which Cabin 1, Cabin 2, Post 1 and Post 2 loudspeakers adopt three-wire system, with volume adjustable and having function of forced full-load output (full-load output during remote control speaking, alarm automatic start-up and program-controlled remote control; during receiving, playing and MIC shout, volume output is adjustable). When shout loudspeaker works, the rest ways will be switched off in forced manner. Except Shout, the other ways can output simultaneously.

4.1.5 Power supply unit is designed to be AC/DC type, AC220V±10%, DC24V±10%. Meeting AC power-off, the unit will automatically switch to 24VDC to guarantee uninterrupted service.

4.2 Remote control station

4.2.1 Remote control station consists of master remote control station (generally it is placed in pilot's cabin in flush-type or wall-mounted manner), No.2 remote control station and No.3 remote control station, etc. Master remote control station is prepared with port/starboard microphone (MIC) interface, and enjoys highest priority class. When master remote control station works, the other remote control stations, intercom, circuit control and broadcasting unit MIC as well as receiver /player will be banned from service.

4.2.2 Priority class of other remote control stations is secondary to that of pilot's cabin remote control station. When main engine is occupied by higher-class remote control station, a busy tone will give cue. 2W/8Ω loudspeaker is built in, or a loudspeaker can be connected externally.

4.2.3 Bow/stern remote control station is a wall-mounted one, or can be customized to weather-proof box structure as user needs. IP rating can reach IP56.

4.3 Loudspeaker

4.3.1 Loudspeaker includes horn loudspeaker, wall-mounted/flush-type loudspeaker,

double-sided loudspeaker and ceiling-mounted loudspeaker, etc. Horn loudspeaker is mainly used outside of cabin, with power of 5W-100W. The rest loudspeakers are used in cabin, with power of 0.5W-5W, adjustable volume and forced full-load control. Loudspeaker port has constant voltage 120V input (General power of loudspeaker must be lower than rated output power of public address set)

5 Turn-on and maintenance

5.1. Confirm correct connection of power supply before turning on the set.

5.1.1 Turn volume potentiometer to proper position and check functions of the public address set, remote control stations, telephone linkage and talkback one by one as the set-up.

5.2 Broadcasting function

5.2.1 Any-way loudspeaker output can be selected by pushing corresponding key switches on the panel.

5.2.2 MIC amplifying

5.2.2.1 After load is well connected as required, turn on broadcasting main engine power supply switch, power supply indicator will light; through MIC Shout to adjust corresponding volume potentiometer to make output volume moderate.

5.2.3 Line amplifying

5.2.3.1 Signal from external equipment such as recorder and receiver, etc can be transmitted to line input interface for amplification. Adjust volume potentiometer to make volume proper. If external equipment line input characteristics do not match this unit's linear input characteristics, corresponding attenuator must be used for matching.

5.2.4 Receiving set

5.2.4.1 Receiver can receive FM broadcasting programs.

5.2.5 MP3 or CD player amplifying

5.2.5.1 Turn on broadcasting main engine power supply switch, 'Power Supply' indicator will light. Then turn on MP3/CD player's power supply switch (tape cassette/CD player power supply indicator will light), load USB/CD, adjust volume potentiometer to make volume output proper.

5.2.6 Remote control function

5.2.6.1 Push down remote control station's working switch. If the main engine is busy at the moment, remote control station loudspeaker will give cue of busy tone. If main engine is idle, loudspeaker will deliver a 3-second cue tone, when it can work: push down selection key on remote control station panel and transmit order of Call to main engine. After the order is processed through main engine, remote control command can be realized and order can be given to corresponding station. If main engine is occupied and higher-class remote control station is urgent to give orders, a Call order can be given at once, and main engine CPU circuit will cut off service of lower-class remote control station at once as soon as it receives Call order from interface circuit, and transmit about 1-second forced insertion tone to the lower-class stations, when the remote control station with higher priority class can use microphone for remote-control command and give orders to corresponding stations.

5.2.6.2 Master remote control station is equipped with external port/starboard microphone (MIC) interface, emergency key (only for use with public address set system having our alarm board; not self-locked) and working key: when transmitting alarm signal, hold portable microphone with left hand, hold on emergency key with right hand, alarm signal can then be switched off for

emergency speaking to the entire ship; release emergency key, transmission of alarm signal can be resumed at once. Working key is prepared for turning on remote control station so as to call other remote control stations or to speak through loudspeaker.

5.2.7 Talkback between remote control stations:

5.2.7.1 Push down working switch on remote control station; after hearing cue tone, instantly select the key of number for the called remote control station on the remote control station panel, to give Call order to main engine. The order, after processed by the main engine, will be transmitted to the called party, which, after receiving the Call signal, can push down working switch for mutual talkback through portable microphone.

5.2.8 Remote control broadcasting

5.2.8.1 Push down working switch on remote control station; after hearing cue tone, instantly select the key of the loudspeaker selected for broadcasting, then you can give broadcasting to the selected loudspeaker through portable microphone;

5.3 PUBLIC

5.3.1 Push down working switch of master remote control station; after hearing cue tone, instantly select the remote control station for PUBLIC, then PUBLIC broadcasting to the selected remote control station can be carried out (PUBLIC to max five branch units at the same time) ;

5.3.2 Push down working switch of master remote control station; after hearing cue tone, instantly select keys for all loudspeaker areas for broadcasting (Shout excluded), then PUBLIC broadcasting to the selected area loudspeakers can be carried out.

5.4 Use program-controlled telephone for remote-control speaking

When main engine is idle or in playing or MIC amplifying, dial "7X" or "8X" (7 8 means order number, 7 for ck-1a and ck-1, 8 for ck-1b: X means area number of loudspeakers): dial "71" or "81" for Deck 1 output, "72" or "82" for Deck 2 output, "73" or "83" for Cabin 1 output, "74" or "84" for Cabin 2 output, "75" or "85" for Post 1 output, "76" or "86" for Post 2 output, dial "77" or "87" for Shout output, dial "78" or "88" for all output without shout), main engine interface circuit will receive order and transmit the order to CPU circuit for processing, and switch off playing and MIC amplifying, when remote-control speaking can be carried out through program-controlled telephone. If the remote control station is in remote control command state, wait for main engine to be idle, then dial "7X" or "8X" for remote control speaking.

5.5 Use general emergency alarm system to broadcast alarm

Public Address Set have the Interface of general emergency alarm. The interface include 5 core Wire(1# for emergency control, 2# for signal input, 3# for remote control, 4# for public ground, 5# for emergency speak control). Press the manual button(a long signal) or the general button(Seven short and one long signal), the public address will force open the output of Deck 1, Deck 2, Cabin 1, Cabin 2, Post 1, Post 2 with the most high volt. in the same time, the indicator of alarm will be lighting.

5.6 Maintenance

5.6.1 Check regularly

5.6.1.1 Guarantee good ventilation with the public address set to avoid influencing service of ship due to breakdown of public address set from overheat.

5.6.1.2 Check for any damage of system cable to prevent low line insulation and avoid damage to the public address set due to short-circuit overload.

5.6.1.3 Test the set's operation keys and functions for normal service.

5.6.2 Remedies for simple troubles

5.6.2.1 Public address set does not work and no power supply indicates: check whether external power supply is delivered to the public address set; whether fuse is blown out; power supply switch and power supply unit.

5.6.2.2 Public address set's monitoring loudspeaker works normally, but external loudspeaker gives no voice: check connection and public address set's master control unit.

5.6.2.3 Public address set's monitoring loudspeaker sounds "Du...Du...", but external loudspeaker is unable to give voice and can not work for playing: check whether external remote control station's working key is reset.

6 Points for attention

6.2 Public address set should be mounted in quiet room with good ventilation, and master remote control station can be installed in driving control console or wall-mounted.

6.2 This set has external port on connection board. User can mount telescopic antenna or outdoor antenna additionally as necessary for actual use. Direction and length of the telescopic antenna can be adjusted so as to change intensity of receiving signal. During use, care should be taken to adjust the device for best service. When using outdoor antenna, proper lightning protection unit must be installed to prevent damage to the unit by lightning.

6.3 System connection can be carried out by referring to system connection diagram as shown in the figures. Pay attention to right connection of AC/DC wire so as to avoid reverse "+" "-" poles of DC power supply. Loudspeaker connection cable's sectional area should not be less than 1.5mm^2 , cable model CJPF/SA; shielding layer should be connected with shell reliably, and Cabin and Post loudspeakers should be connected in right order.

6.4 Horn loudspeaker mounted on deck should be checked regularly for water. Any water, if found, must be removed in time so as to avoid influencing equipment service or damage to the unit.

6.5 In order to avoid whistling from sound feedback, remote control station should be mounted in position far from sound source as far as possible. Any trouble, if found, should be removed as soon as possible.

6.6 If the fuse is blown out, check load and power supply voltage first. After check results show normal state of load and voltage, use same-size fuse for replacement. Don't use fuse of higher current or copper wire as the substitute.

附录 Appendix

安装尺寸图和系统接线图 Installation diagram system wiring drawings

1 CKY-1Q (分体式 F 型) 船用扩音机 (Split, Type F) shipboard public address set

CKY-1Q (分体式 F 型) 船用扩音机主机操作部分 (split, Type F) operating unit of shipboard public address set main engine

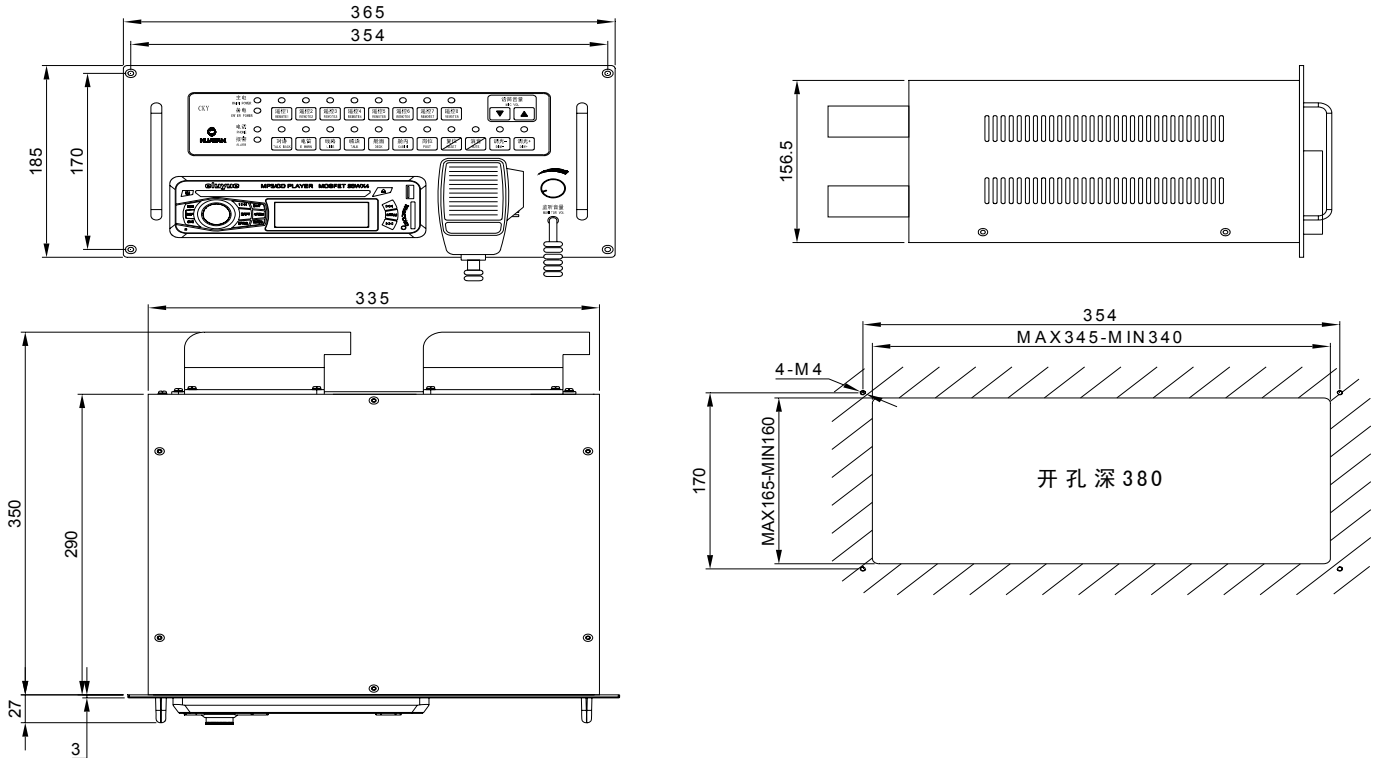

CKY-1Q CKY-1Q (分体式 F 型) 船用扩音机电源功放部分

(split, Type F) Power Amplifier of shipboard public address set power supply

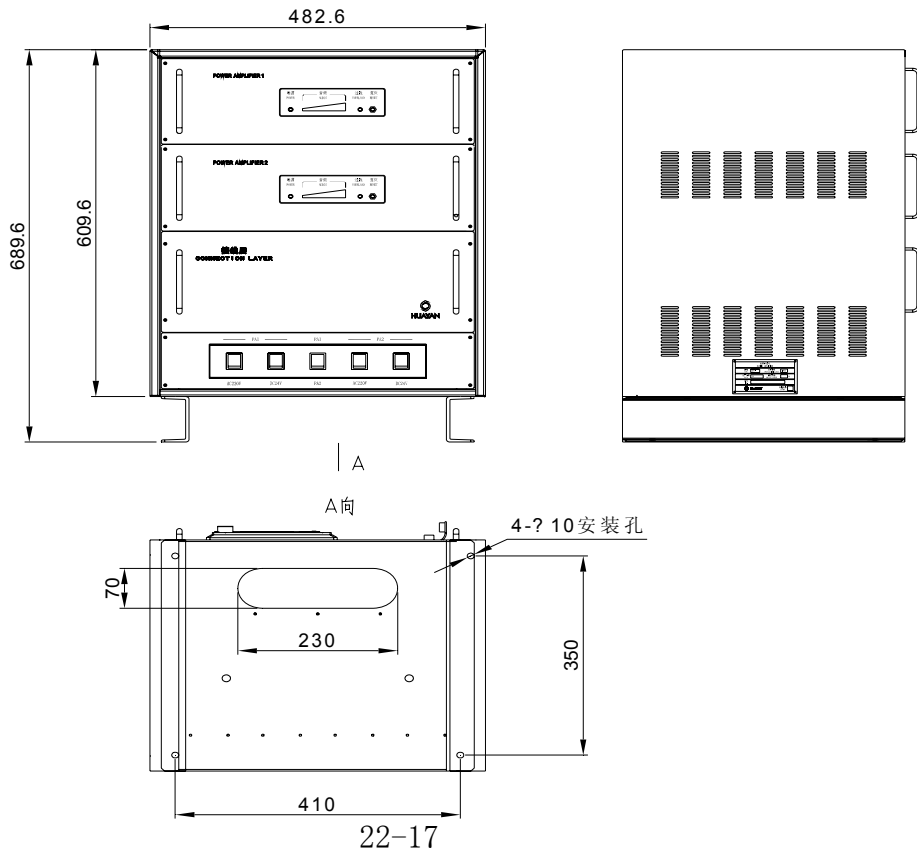

2 CKY-1T (F型) 船用扩音机 (Type F) shipboard public address set

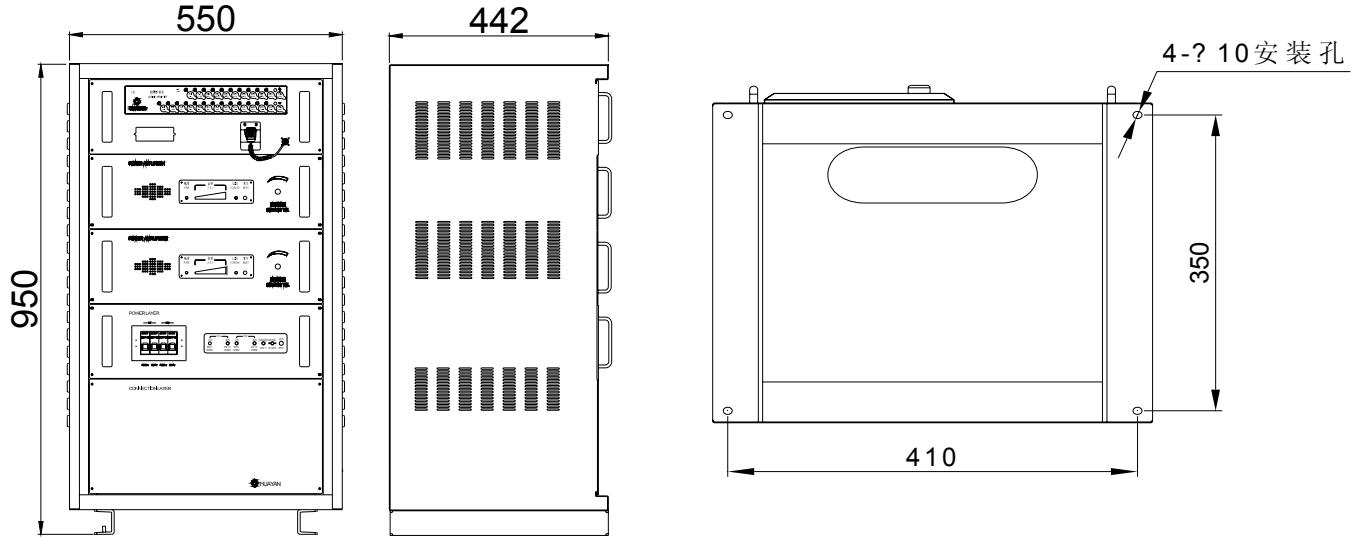

3 CKY-1T/Q (F型) 船用扩音机接线板图 (Type F) diagram of connection board of shipboard public address set

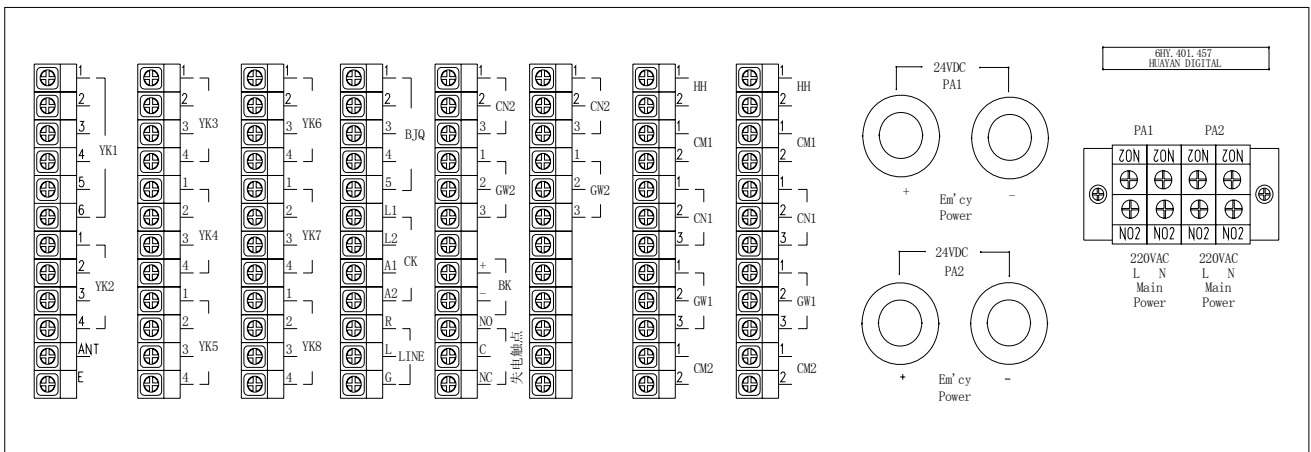

4. YKQ-1Z 嵌入式公共广播主遥控台 Flush-type master remote control station

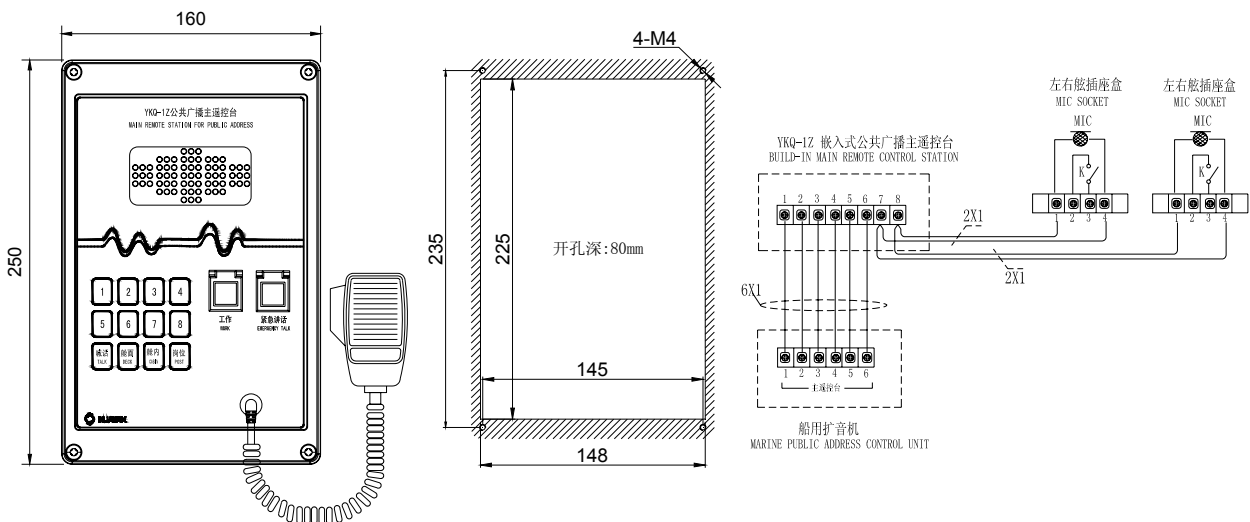

5. YKQ-1 嵌入式公共广播遥控台 Flush-type remote control station

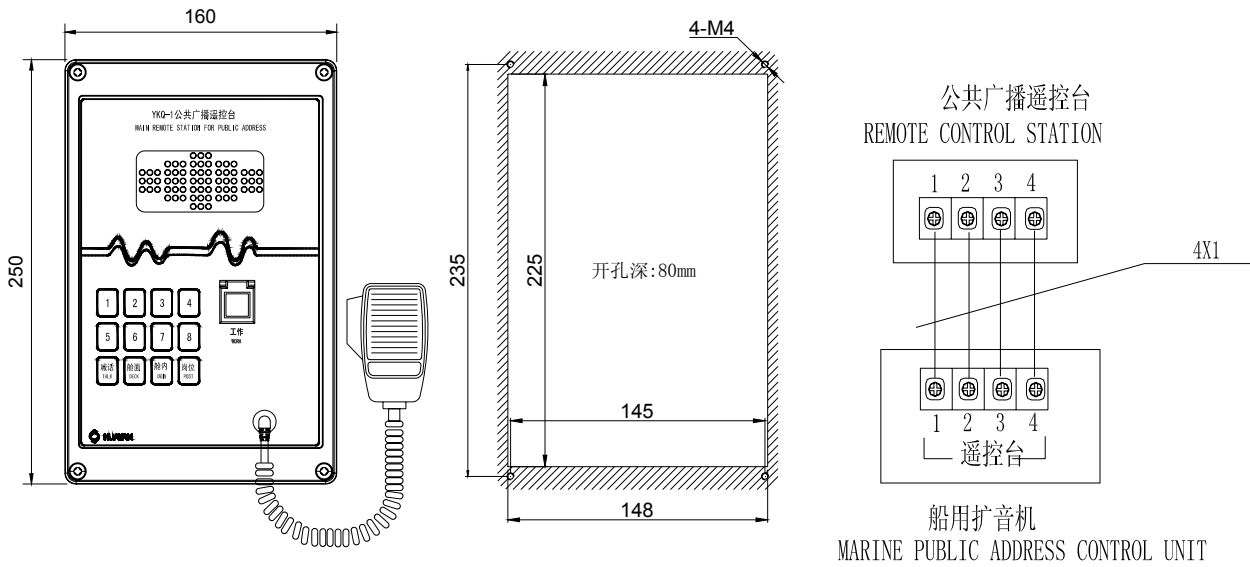

6. YKG-1 壁挂式公共广播遥控台 Wall-mounted remote control station

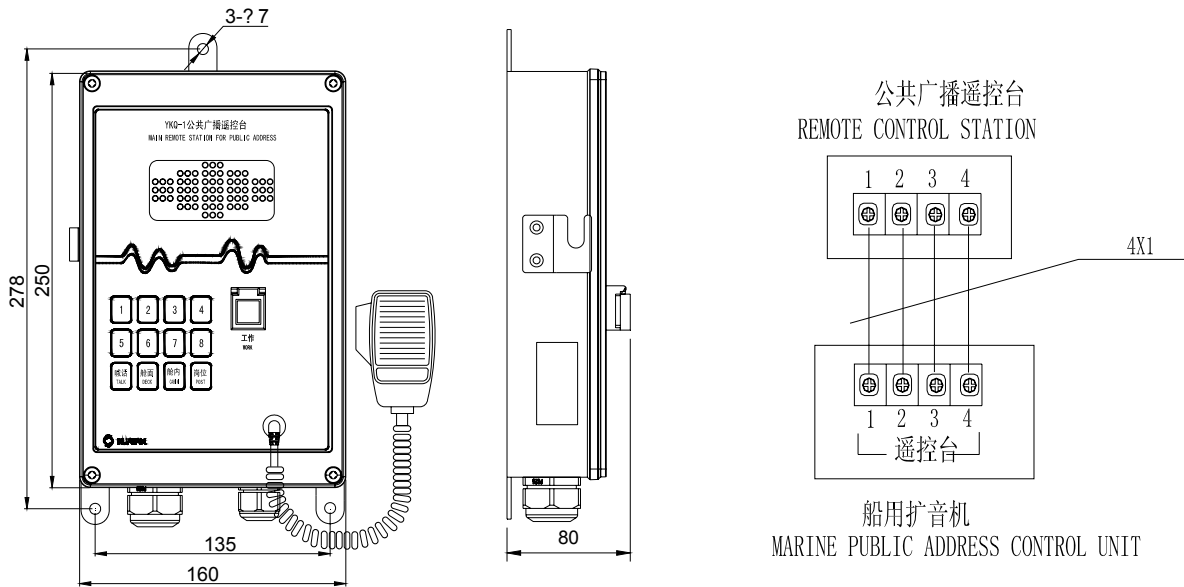

7. YKG-1F 防风雨公共广播遥控台 Weather-proof remote control station

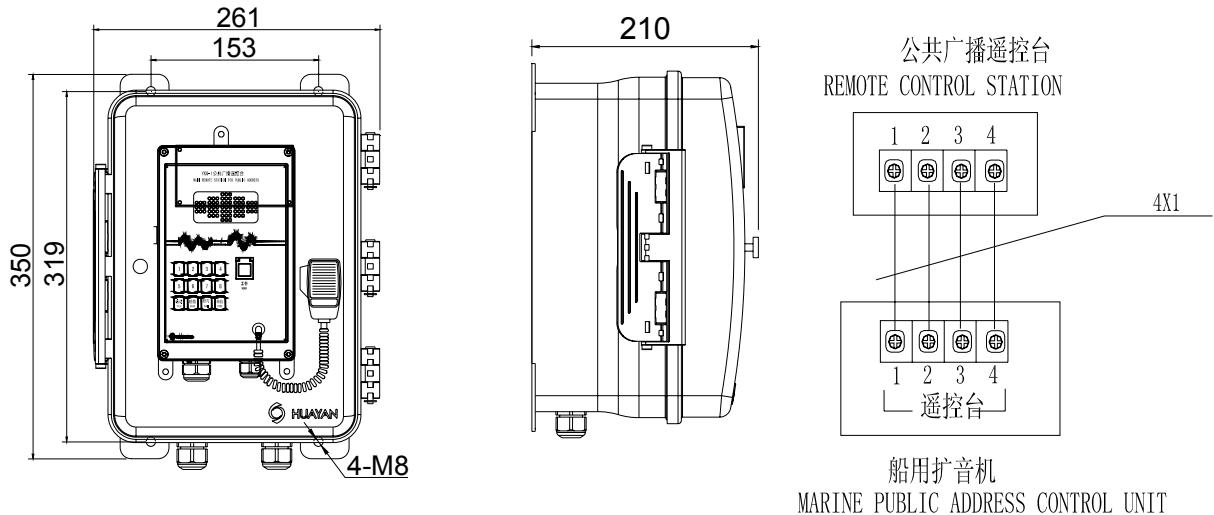

8. YHC (5W/10W) 号筒扬声器 Horn loudspeaker

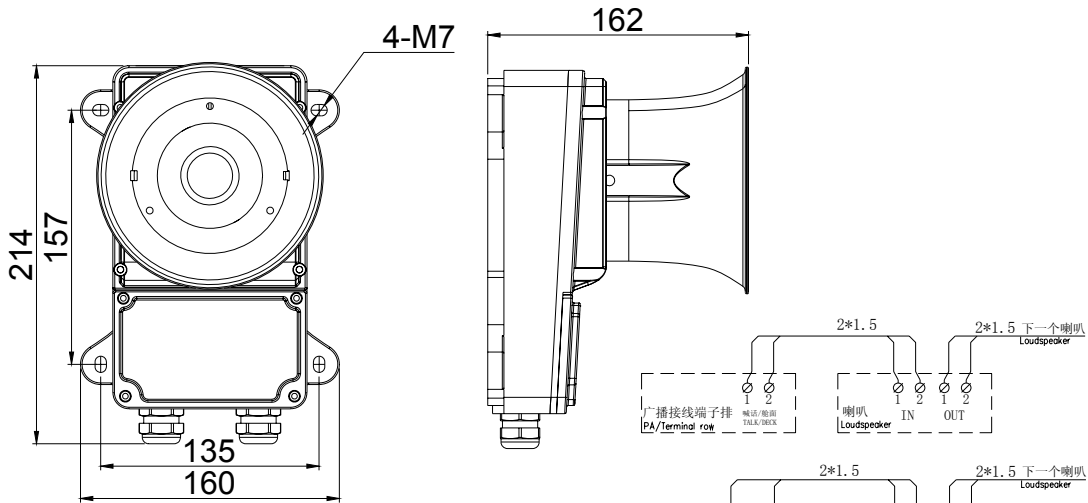

9. YHC (50W/100W) 号筒扬声器 Horn loudspeaker

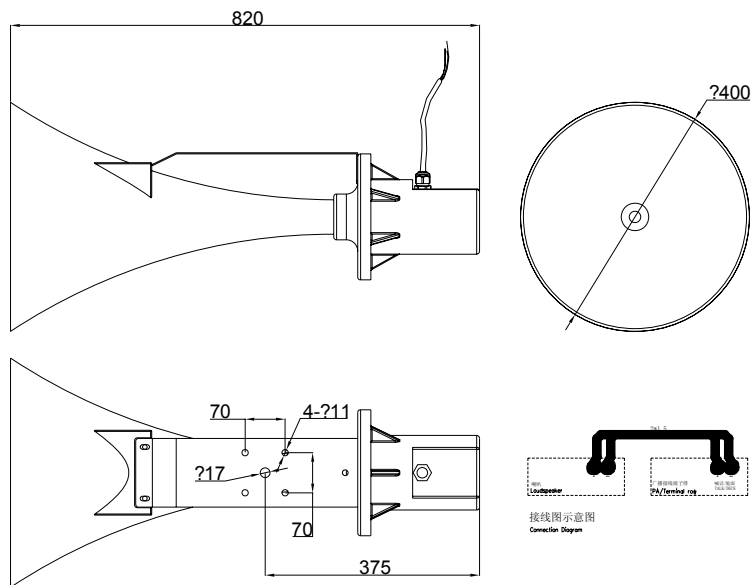

10. YHC (15W/25W) 号筒扬声器 Horn loudspeaker

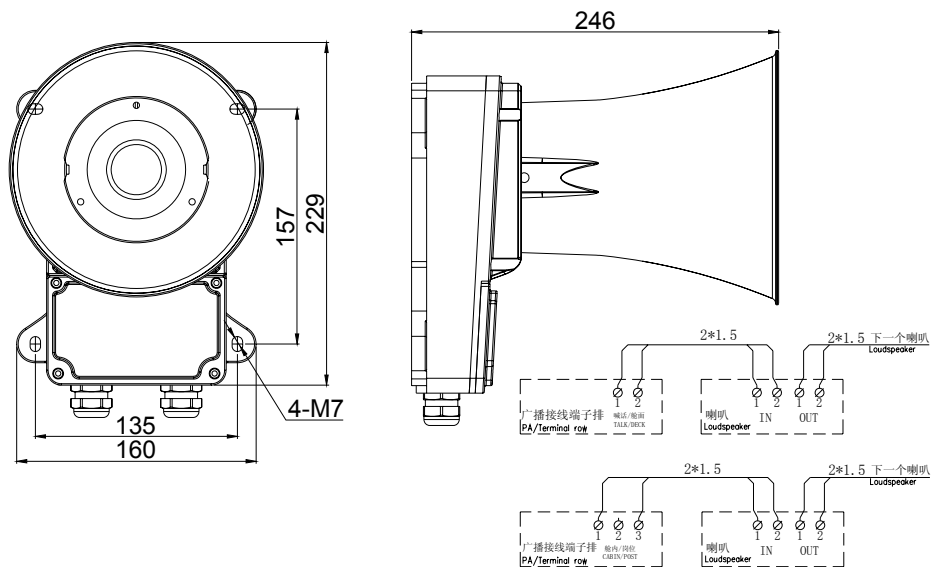

- 11 YSP 防滴式扬声器 Drip-proof loudspeaker
 12 YSG 壁挂式扬声器 Wall-mounted loudspeaker

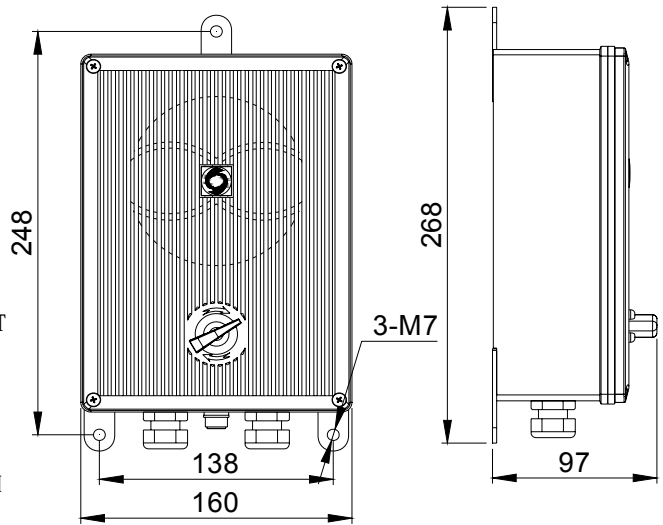
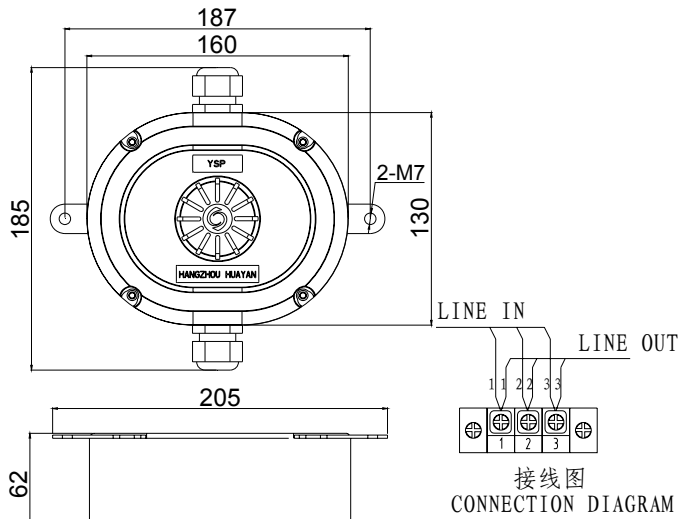

- 13 YSQ 嵌入式扬声器 Flush-type loudspeaker
 14 YSX 吸顶式扬声器 Ceiling-mounted loudspeaker

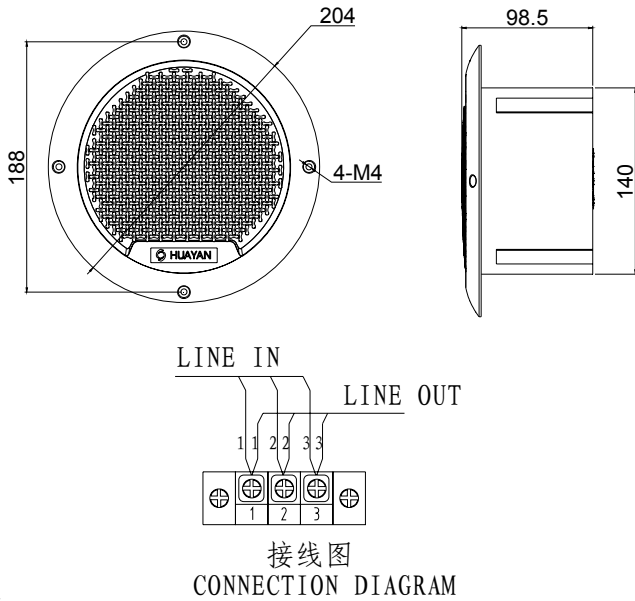
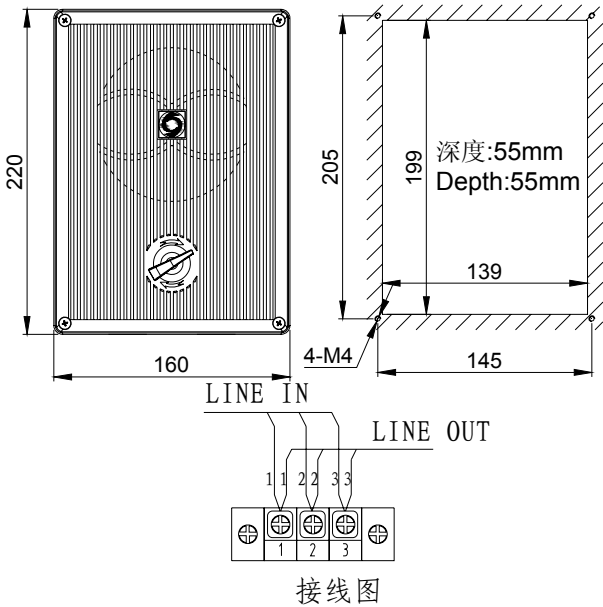

- 15 YSS 双面扬声器 Double-sided loudspeaker

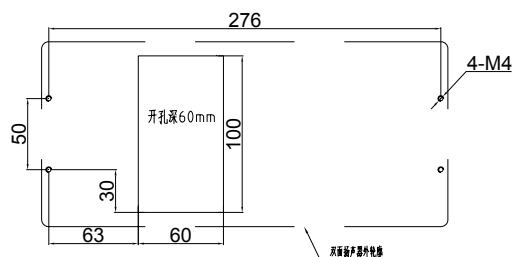
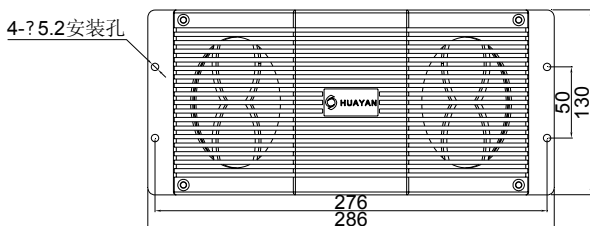
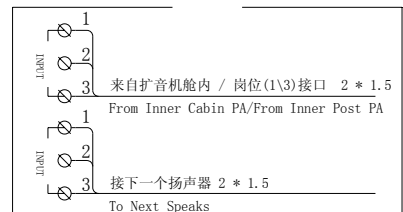
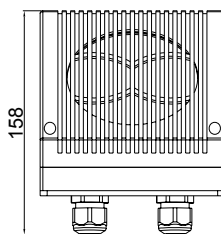
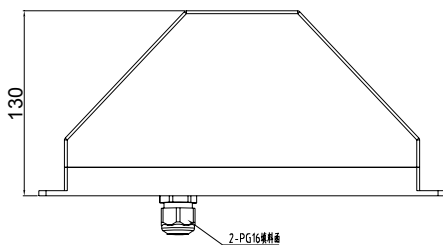

16 CKY-1T 系统接线示意图 System connection diagram

